

HY-DIV168N-3.5A two phase hybrid stepper motor drive manual

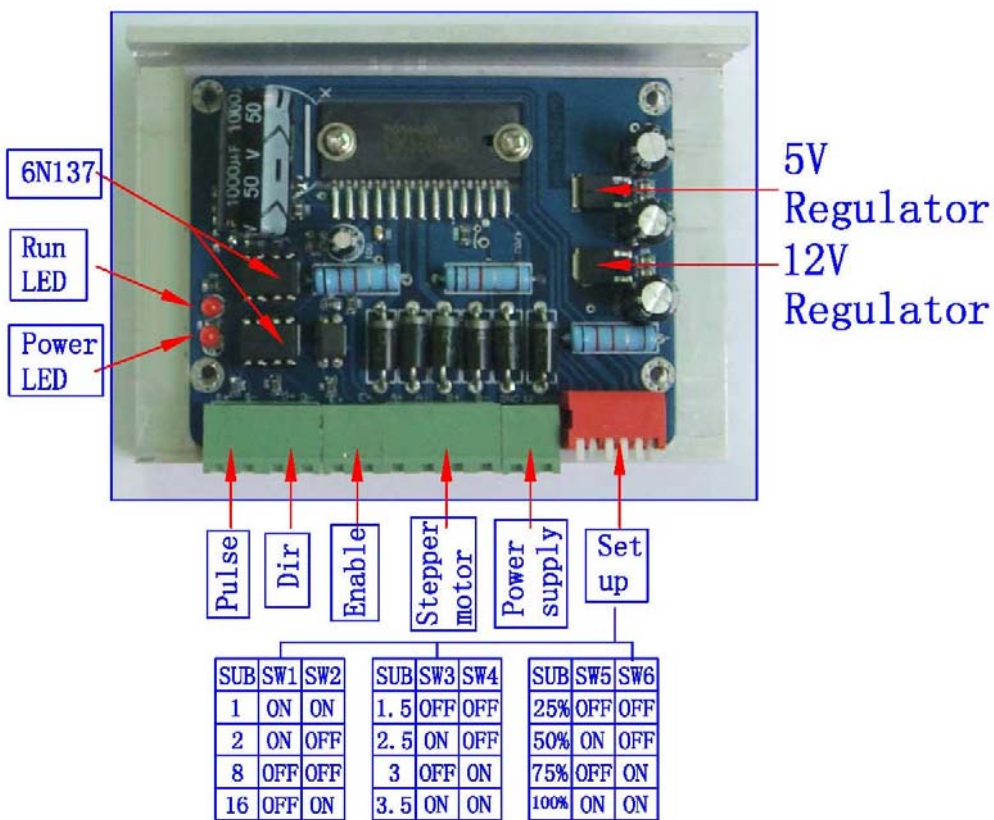

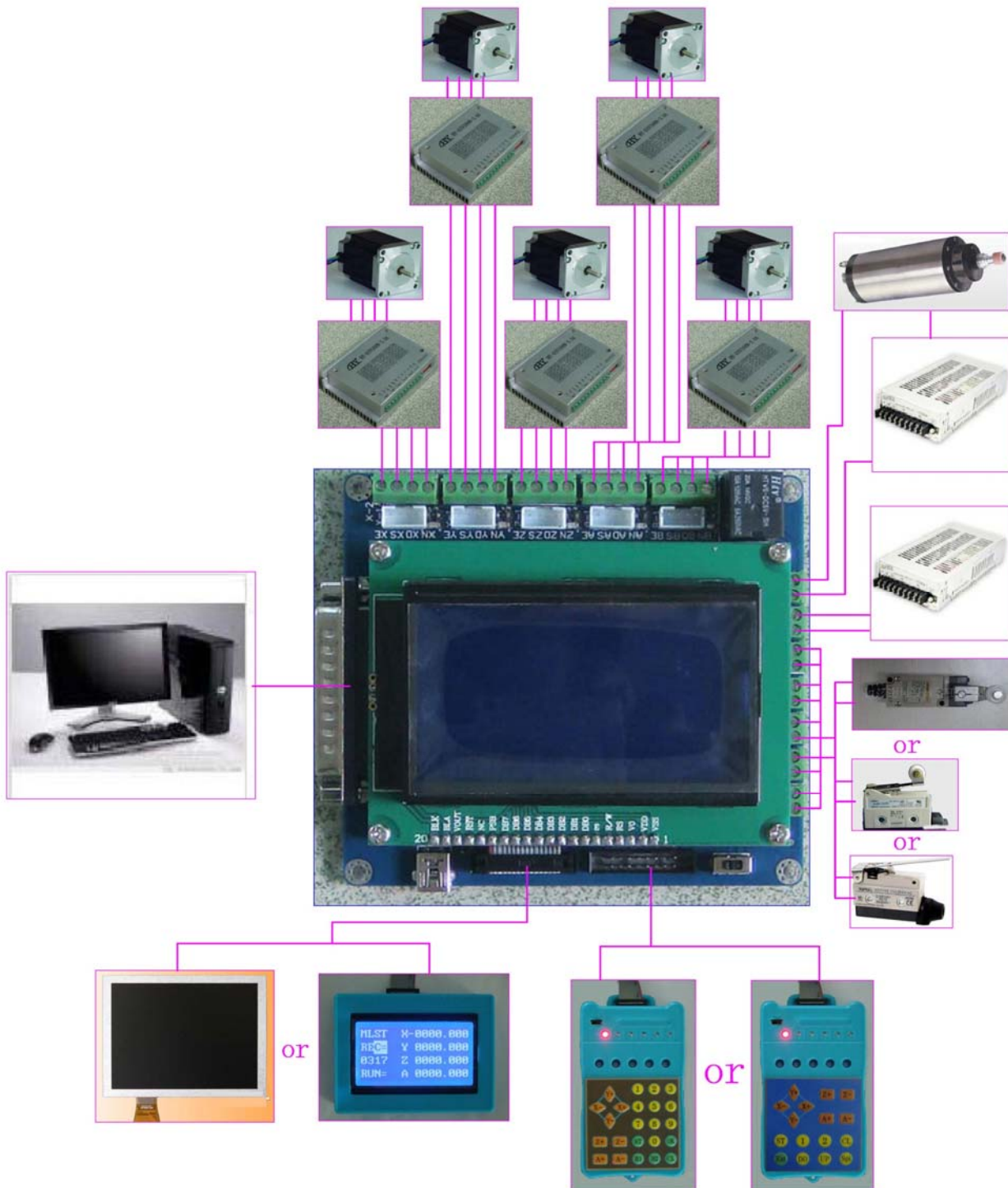

—, an overview

HY-DIV168N-3.5A subdivision-type two-phase hybrid stepping motor drive using DC 12 ~ 36V power supply, suitable for drive

Two-phase hybrid stepping motor dynamic voltage 12 to 36V, the current is less than 3.5A outer diameter of 35 to 86 mm. This drive using the drive's current loop subdivision control, the motor torque ripple is very small, low-speed running is very smooth, almost no vibration and noise. High-speed torque is much higher than other two-phase drive, high positioning accuracy. Widely used in the engraving machine, CNC machine tools, packaging machinery and other high resolution requirements on the device.

The main features

- 1 average current control, two-phase sinusoidal current drive output
- 2 DC 12 ~ 36V power supply, the internal integration of 12V and 5V regulator
- 3 optically isolated signal input / output
- 4, overvoltage, undervoltage, overcurrent, and white short-circuit protection
- 5 4 file segmentation and automatic half-streaming capabilities up to 16 segments
- 4 file output phase current settings
- 7 high starting speed
- 8 high-speed torque

一、 the electrical parameters

Input voltage DC 12 ~ 36V input

The input current of 1 to 4 amps, select the drive a stepper motor.

Output current of 0.5A ~ 3.5A

Temperature Operating Temperature -10 to 45 °C; Storage temperature -40 °C to 70 °C

Humidity not condensing, not drops

Gas prohibit combustible gas and conductive dust

Weight 200 grams

二、 Control signal interface

Figure 1 is a wiring schematic of the drive

1, the definition of control signals

PUL +: step pulse signal is input side or the positive pulse signal input positive terminal

PUL -: the negative input of the negative input pulse signal or a positive pulse signal

DIR +: stepping direction signal input to the positive terminal or negative pulse signal input to the positive terminal

DIR -: stepping direction signal input of the negative side or reverse step pulse signal input negative terminal

EN +: offline can reset signal input side is

EN -: offline can reset signal input negative terminal

Offline enable signal is active, reset drive failure to prohibit any pulse, the output of the drive Power component is turned off, the motor holding torque.

2、 Control signal connections

PC control signal can be high, also can be low effective. When active high, the control signal

The negative side together as a signal to active low, positive side of all control signals together as a signal common.

For example, open-collector and PNP output interface circuit diagram is as follows:

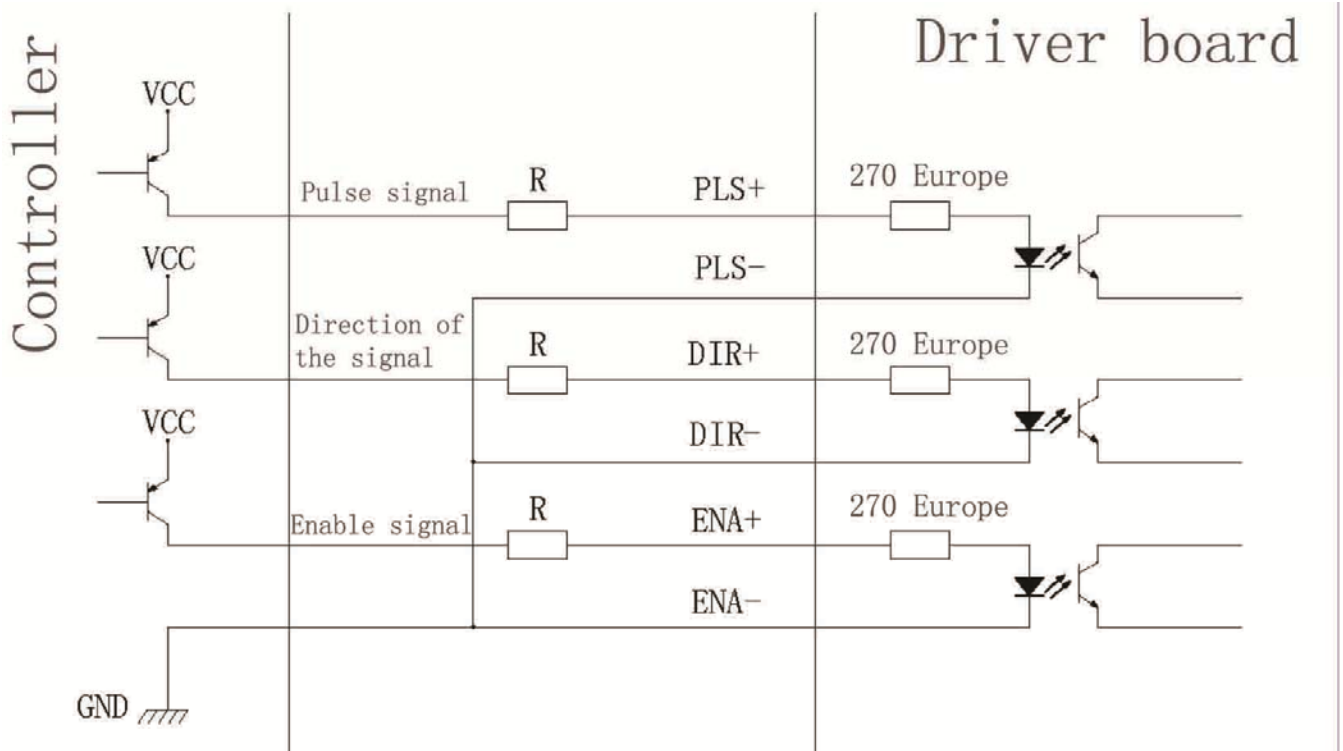

Figure 2. Input interface circuit (common cathode connection)

Note: the VCC is 5V, R short;

VCC value of 12V, R 1K, more than 1/8W resistor;

VCC value of 24V, R 2K, more than 1/8W resistor;

R Must be connected to the controller output terminals.

≡、Function selection (DIP switch on the drive panel)

1、Set the motor per revolution steps

The drive to set the number of steps per motor revolution is 200 (whole step), 400 (2 segments), 1600 (8 segments), 3200 steps (16 segments).

The user can drive the front panel DIP switch SW3 is SW4 bit of the drive to set the number of steps (such as Table 1) :

Subdivision	SW1	SW2
1	ON	ON
2	ON	OFF
8	OFF	OFF
16	OFF	ON

Table 1

2、Set the output phase current

To drive torque stepper motor, the user can drive panel DIP switch

SW1, SW2 is to set the drive output phase current (RMS) unit amperes, the switch position Corresponding to the output current, output current value corresponding different types of drive. Concrete are shown in Table 2.

Output Current (A

Current	SW3	SW4
1. 5A	OFF	OFF
2. 5A	ON	OFF
3. 0A	OFF	ON
3. 5A	ON	ON

Table 2

3、 Current setting

Current	SW5	SW6
25%	OFF	OFF
50%	ON	OFF
75%	OFF	ON
100%	ON	ON

4, the semi-flow functionality

The semi-flow function is a step pulse 500ms, the driver output current is automatically reduced to the rated output current

50%, used to prevent motor heating.

Fourth, the power interface

1, DC +, DC-: to connect the drive power

DC +: DC power level, power supply voltage DC 12 to 36V. The maximum current is 4A. The

DC-: DC power supply negative level.

2, A + A-B + B-: to connect the two-phase hybrid stepping motor

Drive and two-phase hybrid stepper motor's connection with the four-wire system, the motor windings in parallel and series connection, and connection method, high-speed performance, but the drive current is large (for motor winding current of 1.73 times), Connected in series when the drive current is equal to the motor winding current.

Five, the installation

Around to have 20mm of space, can not be placed next to the other heating equipment, to avoid dust, oil mist,

Corrosive gases, high humidity is too big and strong vibration. +

Figure 3.

Six fault diagnosis

1, the status light indicates

RUN: green light in the normal work.

ERR: red light, power, light, power indicator